

KNX LED Dimmer

09.952FA.04247



Important: Read All Instructions Prior to Installation

Function introduction

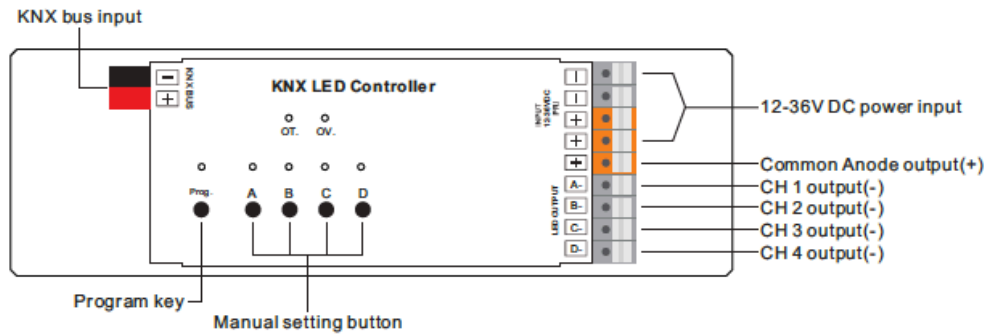

Product Data

No.	Input Voltage	Output Current	Output Power	Remarks	Size(LxWxH)
1	12-36VDC	4x5A	4x(60-180)W	Constant voltage	170x53.4x28mm
2	12-36VDC	4x350mA	4x(4.2-12.6)W	Constant current	170x53.4x28mm
3	12-36VDC	4x700mA	4x(8.4-25.2)W	Constant current	170x53.4x28mm

The dimmer with LED constant voltage drive can drive LED directly, has four channels, each channel is independent.

The output can connect with some big power dimmable LED lights. These LEDs can be switched, dimmed, recall scene or other operations via the bus.

The devices adopt PUSH terminals to achieve electrical connection; the connection to the EIB/KNX bus is established via a bus connecting terminal. The input need connect a 12V-36V DC operation voltage. The following list provides a functional overview:

- ☆ Switching the LED light
- ☆ Relative dimming
- ☆ Absolute dimming
- ☆ Status report, error report
- ☆ Setting 15 scenes
- ☆ Staircase lighting function
- ☆ Bus recovery (or reset) function
- ☆ Preset value and modify preset value functions
- ☆ Switch/relative dimming via manual buttons

The above function of parameters to configure and use are described in the chapter 5. The device has own database file. There is added a manual operation function in the normal dimming mode, it is invalid in the staircase lighting mode. Switch via a short operation of manual buttons, relative dimming via a long operation, and in the case of the bus voltage fail the manual operation is invalid.

Safety & Warnings

- DO NOT install with power applied to device.
- DO NOT expose the device to moisture.

Technical data

Power supply	Bus Operating voltage	21-30V DC, via the KNX/EIB bus
	Input voltage	12-36V DC
Output	4 channels	
	Rated current	5A/350mA/700mA×4CH
	Load voltage	12-36V DC (constant voltage)
	Safety	Short-circuit, over voltage and over temperature protection
Connections	EIB/KNX	EIB bus connection terminal
	Inputs/outputs	Using screwless connection terminal
Operation and display	Button and red LED	For assigning the physical address
	Green LED flashing	Indicate the application layer running normally
	LEDs for Output	Indicate output status per channel, LED on mean the channel has output, LED off mean the channel has not output.
	Manual buttons	Switch via a short operation, relative dimming via a long operation
	OT. LED	Indicate over-temperature, >70 °C
	OV. LED	Indicate over voltage, >40V DC
Type of protection	IP 20, EN 60 529	
Temperature	Operation	-5 °C...+45°C
	Storage	-25 °C...+55°C
	Transport	-25 °C...+70°C
Ambient	Humidity	<93%, except dewing

Wiring diagram

