

# EAE ORIA SWITCH

Product Manual Oria Switch



## Contents

1. General .....	3
2. Device Technology .....	3
2.1 Button Definitions .....	3
2.2 Connection Diagram .....	3
2.3 Technical Data .....	4
2.4 Dimensions .....	4
3. Communication Object Table .....	5
4. Parameters and CommunicationObjects .....	6
4.1 General .....	6
4.1.1 Parameters .....	6
4.1.2 Communication Objects .....	7
4.2 Rockers and PushButtons .....	7
4.2.1 Rockers .....	8
4.2.2 Push Buttons .....	16

## 1. General

Extendable up to 6 folds, Oria KNX switches offer a wide range of functional flexibility with programmable buttons.

Buttons on Oria switches can be programmed to control lighting, shutter/blind drivers, speakers, make scene calls and mimic panic buttons. Each button can be programmed independently for a different function.

## 2. Device Technology

### 2.1 Button Definitions

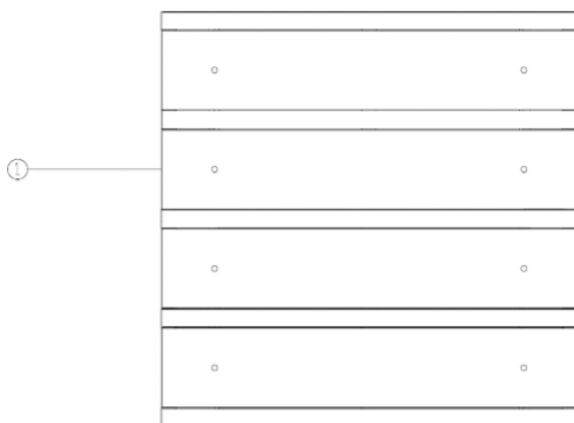

1. Programmable Button Groups (up to 6 folds)

### 2.2 Connection Diagram

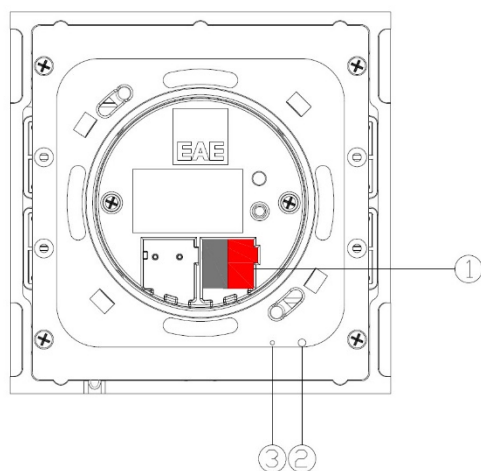

1. KNX Port Terminal
2. Programming Button
3. Programming LED

## 2.3 Technical Data

Protection Type	IP20	EN 60529
Safety Class	II	EN 61140
Supply	Voltage Range Supply Voltage  Power Consumption	21-30V DC, Supply from EIB/KNX line  <10 mA  <10 mA x 30V
Operation LEDs	Programming LED for each fold	1 to 5 RGB LEDs for physical address identification
Button Operation Life	100.000	
Temperature	Operating  Storage  Transport	-5° C + 45° C  -25° C + 55° C  -25° C + 70° C
CE	In accordance with EMC guideline and low voltage regulation	

## 2.4 Dimensions

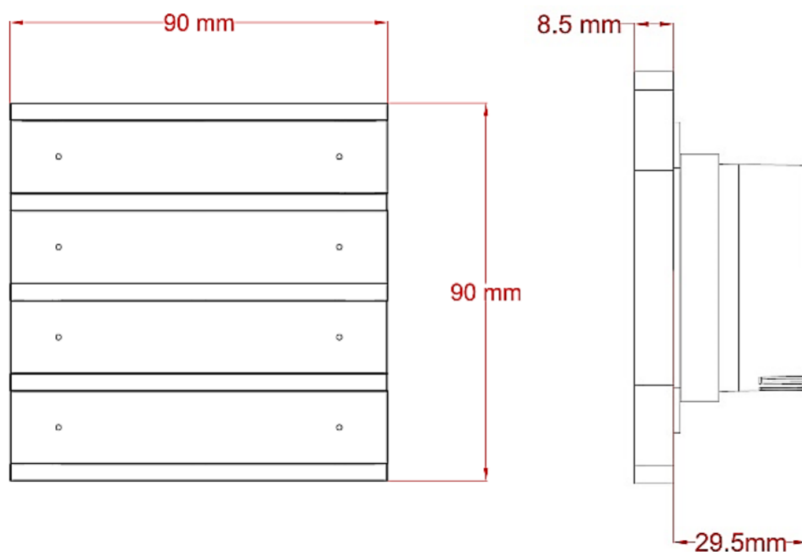

### 3. Communication Object Table

No.	Object Name	Function	Number of Bits	Flags
0	General, operation	Active	1	CT
1	Rocker 1, switch	On/Off	1	CWT
	Rocker 1, shutter	Up/Down	1	CWT
	Rocker 1, value[0,1]	Send	1	CWT
	Rocker 1, value[0...255]	Send	8	CWT
	Rocker 1, value[0...65535]	Send	16	CWT
	Rocker 1, value[-32768...32768]	Send	32	CWT
	Rocker 1, value[0...4294967295]	Send	64	CWT
	Rocker 1, value.temperature	Send	64	CWT
	Button 1, switch	On/Off	1	CWT
	Button 1, shutter	Up/Down	1	CWT
	Button 1, value[0,1]	On/Off	1	CWT
	Button 1, value[0...255]	Send	8	CWT
	Button 1, value[0..65535]	Send	16	CWT
	Button 1, value[-32768...32768]	Send	32	CWT
	Button 1, value[0...4294967295]	Send	64	CWT
	Button 1, value.temperature	Send	64	CWT
2	Rocker 1, dimming	Send	4	CWT
	Rocker 1, shutter	Stop/Lamella Adj	1	CWT
	Button 1, dimming	Send	4	CWT
	Button 1, shutter	Stop/Lamella Adj	1	CWT
	Button 1, value[0,1]	On/Off	1	CWT
	Button 1, value[0...255]	Send	8	CWT
	Button 1, value[0...65535]	Send	16	CWT
	Button 1, value[-32768...32768]	Send	32	CWT
	Button 1, value[0...4294967295]	Send	64	CWT
	Button 1, value.temperature	Send	64	CWT
3	Rocker 1, shutter	Top Position	1	CWT
	Rocker 1, status	Top Position	1	CWT
	Button 1, shutter	Top Position	1	CWT
	Button 1, status	Top Position	1	CWT
4	Rocker 1, shutter	Bottom Position	1	CWT
	Button 1, shutter	Bottom Position	1	CWT

## 4. Parameters and Communication Objects

### 4.1 General

General parameters include configuration of “in operation bit”, total rocker count, telegram limitations, window status, LED and LCD controls.

#### 1.1.2 SMx Push button > General

Figure 1

#### 4.1.1 Parameters

Parameter	Settings	Description
Enable In Operation	Enable/Disable	In operation can be used to ensure that device is alive and connected to KNX line.
In Operation Bit	Off/On	Visible when “Enable In Operation” enabled. Bit value to send as device alive operation
In Operation Send Interval[sec]	0...300...65535	Visible when “Enable In Operation” enabled. Cyclic time period for sending in operation bit
Enable Telegram Limit	Enable/Disable	Limits the number of telegrams to send in certain time period
Telegram Limit Period Duration	50ms, 100ms, ..., 30sn, 1min	Visible when “Enable Telegram Limit” enabled. Time period to check telegram numbers

Maximum Telegram Count in Period	1..100...255	Visible when “Enable Telegram Limit” enabled. Maximum number of telegrams to send in telegram limit period duration
Light Duration of LED	0,75s, 2.25s, 3.25s	LEDs on duration when status LEDs used as status indication with rocker or push buttons.
Rocker Count	1, 2, 3, 4, 5, 6	Number of rockers should be selected compatible with device to be able to use rockers and push buttons correctly.

Table 2

\*[1] LCD Backlight Control: Additional to the LCD backlight control through “LCD Backlight Control” parameter, LCD has another method to control backlight. Pressing “Setpoint Decrease Button” for longer than 6 seconds will dim the backlight to %10 brightness. If the LCD backlight control is selected as “Dimmed After Timeout”, pressing buttons will no longer have any effect on the backlight brightness. Pressing “Setpoint Increase Button” for longer than 6 seconds causes the brightness levels to return to normal mode.

#### 4.1.2 Communication Objects

No	Object Name	Function	Data Type	Flags
0	General – In operation	Active	1 Bit DPT 1.002	CT

In operation value (0,1) selected through “In operation bit” parameter will be send via the group address which is linked to this communication object

Table 3

## 4.2 Rockers and PushButtons

Total number of rockers can be selected through “Rocker Count” parameter in “General” tab. Buttons on the thermostat can be used as rockers or push buttons. Select the desired operation from the “Rocker N” (N: Rocker number) tab (Figure 2). If configured as push buttons, 2 push button tabs will be visible under “Rocker N” tab (Figure 3). Both rockers and push button have 5 functions, no function, switch, switch and dim, shutter and value operation.

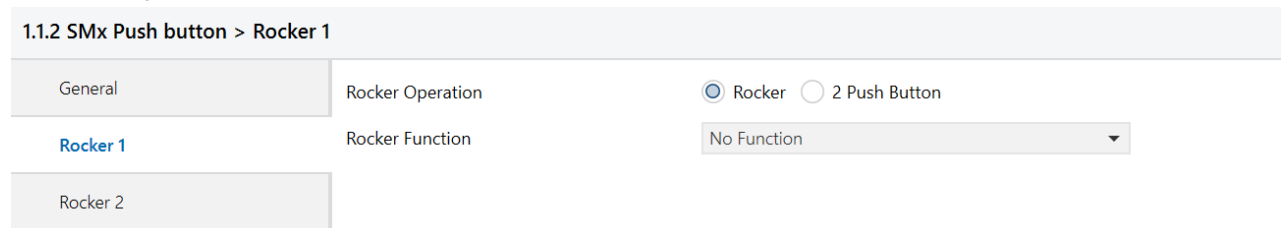

Figure 2

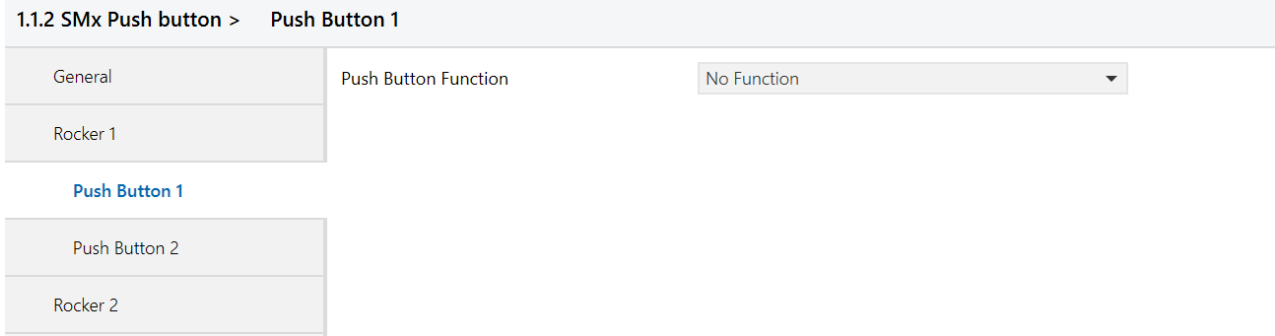

Figure 3

### 4.2.1 Rockers

Number of rockers should be selected in “General” tabs in parameters and should be chosen as compatible with the device that will be configured. Rockers are numbered from top to bottom, topmost rocker as Rocker 1, below it Rocker 2, and so on. Rockers can be configured as 4 different operations and 1 function to disable rocker (No Function). Operation selection can be configured with “Rocker Function” parameter. Every function enables different parameters and communication objects that will be explained in the following chapters.

Parameter	Setting	Description
Rocker Operation	<b>Rocker/2 Push Button</b>	Selects the function of rocker
Rocker Function	<b>No Function</b>	Disables the rocker
	Switch	Rocker can be used to send on/off telegrams. (For more information Chapter 4.2.1.1)
	Switch and Dim	Rocker can send on/off and dimming telegrams. (For more information Chapter 4.2.1.2)
	Shutter	Rocker can control shutter, venetian blind, blind, roller and awning. (For more information Chapter 4.2.1.3)
	Value Operation	Rocker buttons can send predefined values from different data types. (For more information Chapter 4.2.1.4)

Table 4

Rockers also have status LEDs which can be configured to indicate state of the operation that is configure.

#### 4.2.1.1.1 Switch

Selecting “Switch” as “Rocker Function” enables to send 1 bit On(1)/Off(0) telegrams to the group address that is linked to respective communication object. Status LEDs can be configured to notify the current status of operation directly with buttons or using communication objects for confirmation to show current status.



1.1.2 SMx Push button > Rocker 1

General	Rocker Operation	<input checked="" type="radio"/> Rocker <input type="radio"/> 2 Push Button
Rocker 1	Rocker Function	Switch
Rocker 2	Mode Of Buttons	<input checked="" type="radio"/> Left Button On Right Button Off <input type="radio"/> Left Button Off Right Button On
	Function Of LED	Status Indication
	Separate Comm Object	<input type="radio"/> Enable <input checked="" type="radio"/> Disable

Figure 4

4.2.1.1.1 Parameters

Parameter	Setting	Description
Mode of Buttons	<b>Left Button On Right Button Off</b> Left Button Off Right Button On	Select which button is ON button and which button is OFF button
Function of LED	<b>LED permanently Off</b>	LED always Off
	LED permanently On	LED always On
	Status Indication	Status LED of last pressed rocker button is on, other rocker button is off. If “Separate Comm Object” parameter selected as “Enable” status LEDs will wait for confirmation from communication object before changing state.
	Inverted Status Indication	Status LED of last pressed rocker button is off, other rocker button is on. If “Separate Comm Object” parameter selected as “Enable” status LEDs will wait for confirmation from communication object before changing state.
	Operation Indication	Status LED of the pressed rocker button will be on for the time period selected at “Light Duration of LED” parameter at “General” tab.
Separate Comm Object	Enable/Disable	Only visible when “Function of LED” selected as “Status Indication” or “Inverted Status Indication”. This communication objects is the input of confirmation for status LEDs. If selected “Enable” respective communication object should be linked to an appropriate group address

Table 5

4.2.1.1.2 Communication Objects

No	Object Name	Function	Data Type	Flags
1	Rocker1 – Telegr.switch	On/Off	1 bit DPT 1.001	CWT
On/Off telegrams will be send to group address that is linked to this communication object.				
3	Rocker1 – Status Comm.Obj.	On/Off	1 bit DPT 1.002	CWT
Confirmation for On/Off switch telegrams will be received from this communication object. If these communications object visible, it must link to an appropriate group address. Otherwise status LEDs will not function correctly. If status confirmation not to be used the communication object should be disabled by “Separate Comm Object” parameter.				

Table 6

4.2.1.2 Switch and Dim

1.1.2 SMx Push button > Rocker 1

General	Rocker Operation	<input checked="" type="radio"/> Rocker <input type="radio"/> 2 Push Button
Rocker 1	Rocker Function	Switch And Dim
Rocker 2	Mode Of Buttons	<input checked="" type="radio"/> Left Button Brighter(On) Right Button Darker(O... <input type="radio"/> Left Button Darker(Off) Right Button Brighter(O...
	Long Press Duration	1s
	Dimming Type	<input type="radio"/> Start Stop <input checked="" type="radio"/> Step Wise
	Step Value	1.56%
	Step Send Interval	1s
	Function Of LED	Status Indication
	Separate Comm Object	<input type="radio"/> Enable <input checked="" type="radio"/> Disable

Figure 5

Rockers can be configured with switching and dimming capability. When configured as “Switch and Dim” rocker buttons will have two modes switch mode and dim mode. When rocker button pressed shorter than time period specified in “Long Press Duration” parameter, rocker button will act as a switch. In switch mode rocker buttons will behave as normal switches as explained in Chapter 4.1.1. When rocker buttons pressed longer than “Long Press Duration” rocker will enter “Dim mode”. Dimming capability can be used in two different types “Start Stop” and “Step Wise”. Which type to use can be configured in “Dimming Type” parameter.

**Dimming - Start Stop Type**

When rocker button pressed (and not released) and pressed duration exceeds “Long Press Duration” time “Increase, %100”(When on button pressed) or “Decrease, %100”(When off button pressed) dimming level will be send using respective communication object. When button is released “Increase, Break” or “Decrease, Break” value will be sent to stop dimming operation.

**Dimming - Step Wise Type**

When rocker button pressed (and not released) and pressed duration exceeds “Long Press Duration” time, a step value level configured in “Step Value” parameter will be send using respective communication object. Until button is released same step value will be send periodically with a time interval defined in “Step Send Interval”.

4.2.1.2.1 Parameters

Parameter	Setting	Description
Mode of Buttons	<b>Left Button Brighter(On) Right Button Darker(Off)</b> / Left Button Brighter(Off) Right Button Darker(On)	Select which rocker button is on button and which rocker button is off button
Long Press Duration	300ms/400ms/500ms/600ms/800ms/ <b>1s</b> / 1.2s / 1.5s/2s/3s/4s/5s/6s/7s/8s/9s/10s	Time interval to switch from “switch mode” to “dimming mode”.
Dimming Type	<b>Start Stop</b> / Step Wise	Select dimming type. (Chapter 4.2.1.2)

Step Value	%100/%50/%25/%12.5/%6.25/%3.13/ % 1.56	Visible when dimming type is Step Wise. Selects the dimming resolution that will be sending at every "Step Send Interval".
Step Send Interval	300ms/400ms/500ms/600ms/800ms/1s/ 1.2s/1.5s/2s/3s/4s/5s/6s/7s/8s/9s/ 10s	Visible when dimming type is Step Wise. Selects the time interval to send dimming increase/decrease values
Function of LED	<b>LED Permanently Off</b>	LED always off
	LED Permanently On	LED always on
	Status Indication	Status LED of last pressed rocker button is on, other rocker button is off. If "Separate Comm Object" parameter selected as "Enable" status LEDs will wait for confirmation from communication object before changing state.
	Inverted Status Indication	Status LED of last pressed rocker button is off, other rocker button is on. If "Separate Comm Object" parameter selected as "Enable" status LEDs will wait for confirmation from communication object before changing state.
	Operation Indication	Status LED of the pressed rocker button will be on for the time period selected at "Light Duration of LED" parameter at "General" tab.
Separate Comm Object	Enable / Disable	Only visible when "Function of LED" selected as "Status Indication" or "Inverted Status Indication". This communication objects is the input of confirmation for status LEDs. If selected as "Enable" respective communication object should be linked to an appropriate group address

Table 7

#### 4.2.1.2.2 Communication Objects

No	Object Name	Function	Data type	Flags
1	Rocker1 – switch	On/Off	1 bit DPT 1.001	CWT
On/Off telegrams will be send to group address that is linked to this communication object.				
2	Rocker1 – dimming	Dim	4 bit DPT 3.007	CWT
Dimming values will be send to group address that is linked to this communication object.				
3	Rocker1-Status Comm.Obj.	On/Off	1 bit DPT 1.002	CWT
Confirmation for On/Off switch telegrams will be received from this communication object. If these communication object visible, it must link to an appropriate group address. Otherwise status LEDs will not function correctly. If status confirmation not to be used the communication object should be disabled by "Separate Comm Object" parameter.				

Table 8

1.1.2 SMx Push button > Rocker 1

General	Rocker Operation	<input checked="" type="radio"/> Rocker <input type="radio"/> 2 Push Button
Rocker 1	Rocker Function	Shutter
Rocker 2	Mode Of Buttons	<input checked="" type="radio"/> Left Up Right Down <input type="radio"/> Left Down Right Up
	Control Type	<input checked="" type="radio"/> Shutter/Venetian blind <input type="radio"/> Blind/Roller/Awning
	Function Of LED	LED Permanently Off
	Long Press Duration	800ms
	Long Press --> Up/Down, Short Press --> Stop/Lamella Adj.	

Figure 6

Selecting “Shutter” for “Rocker Operation” enables shutter operation for rocker buttons. Shutter functions can be configured to control two different shutter operations “Shutter/Venetian Blind” function or “Blind/Roller/Awning” function.

Shutter/Venetian Blind Function

Firstly, select which rocker button is used for “up” operation, which rocker button is used for “down” operation by “Mode of Buttons” parameter. Both buttons have two functions as “short press” function and “long press” function, “Long Press Duration” parameter configures the limit time period for “long press” operation. “Long Press” will be used to move the blind upwards or downwards. “Short press” has two different functions whether blind is moving or not. When blind is moving “short press” acts as a stop button that stops the blinds movement, when blind is not moving “short press” function is used to adjust lamella position.

	Short Press	Long press
Up Button – Blind Moving	Stop	Up
Down Button – Blind Moving	Stop	Down
Up Button – Blind Stopped	Lamella Down	Up
Down Button – Blind Stopped	Lamella Up	Down

Table 9

When “Up Button” long pressed “Up” telegram will be transmitted using “Rocker1 – Shutter UP/DOWN” communication object and shutter will start moving upwards until it reaches “Top Position” or “STOP” telegram transmitted using “Rocker1 – STOP/Lamella Adj.” communication object by short pressing “Up Button” or “Down Button”.

When “Down Button” long pressed “Down” telegram will be transmitted using “Rocker1 – Shutter UP/DOWN” communication object and shutter will start moving downwards until it reaches “Bottom Position” or “STOP” telegram transmitted using “Rocker1 – STOP/Lamella Adj.” communication object by short pressing “Up Button” or “Down Button”.

When blind is not moving “Up Button” and “Down Button” operate as lamella adjustment and respective telegram will be send using “Rocker1-STOP/Lamella Adj.” communication object.

Blind/Roller/Awning Function

Selecting “Control Type” parameter as “Blind/Roller/Awning” disables lamella adjustment functions of rocker buttons. In this control type, when “Up Button” pressed “Up” telegram will be send using “Rocker1 – shutter. UP/DOWN” communication object and pressed again while blind is moving “STOP” telegram will be send using “Rocker1 – STOP/Lamella adj.” communication object. When “Down Button” pressed “DOWN” telegram will be sending using “Rocker1 – shutter. UP/DOWN” communication object and pressed again while blind is moving “STOP” telegram will be send using “Rocker1 – STOP/Lamella adj.” communication object.

#### 4.2.1.3.1 Parameters

Parameter	Setting	Description
Mode of Buttons	<b>Left Up Right Down</b> Left Down Right Up	Select which rocker button is “Up Button” and which rocker button is “Down Button”.
Control Type	<b>Shutter/Venetian Blind</b> Blind/Roller/Awning	Selects control type of blinds. Shutter/Venetian Blind function includes “Lamella Control” and Blind/Roller/Awning function does not include “Lamella Control”.
Function of LED	<b>LED Permanently Off</b>	LED always off
	LED Permanently On	LED always on
	Status Indication	Visualize blind’s state using status LEDs of up and down buttons. <b>*[5]</b>
	Operation Indication	Status LED of the pressed rocker button will be on for the time period selected at “Light Duration of LED” parameter at “General” tab.
Long Press Duration	300ms/ 400ms/ 500ms/ 600ms/ <b>800ms</b> / 1s / 1.2s / 1.5s/ 2s / 3s / 4s / 5s / 6s / 7s / 8s / 9s / 10s	Time interval to switch from short press to long press

Table 10

#### \*[5] LED Function – Status Indication

Status indication operates the same way for “Shutter/Venetian Blind” and “Blind/Roller/Awning”. LEDs status respective to blind’s state is given below

	Up Button - Status LED	Down Button - Status LED
Moving upward	Blink	Off
Moving downward	Off	Blink
At top position	On	Off
At bottom position	Off	On
Stop between top - bottom	Off	Off

Table 11

When “Function of Led” selected as “Status Indication”, “Top Position” and “Bottom Position” communication objects given below must be linked to the appropriate group addresses for the status LEDs to function correctly.

4.2.1.3.2 Communication Objects

No	Object Name	Function	Data Type	Flags
1	Rocker1-shutter UP/DOWN	Up/Down	1 bit DPT 1.008	CWT
This communication object will be used to start blind movement.				
2	Rocker1 – STOP/Lamella adj.	Stop/Lamella adj.	1 bit DPT 1.002	CWT
When “Control Type” parameter is “Shutter/Venetian Blind” this communication object is used to stop movement of blind and adjust lamella position, otherwise when “Control Type” parameter is “Blind/Roller/Awning” only used for stopping blind movement.				
3	Rocker1-Top Position	True/False	1 bit DPT 1.002	CWT
This communication object should be linked to an appropriate group address that will be used to detect whether blind is at “Top Position” (True) or not (False).				
4	Rocker1-Bottom Position	True/False	1 bit DPT 1.002	CWT
This communication object should be linked to an appropriate group address that will be used to detect whether blind is at “Bottom Position” (True) or not (False).				

Table 12

4.2.1.4 Value Operation

1.1.2 SMx Push button > Rocker 1

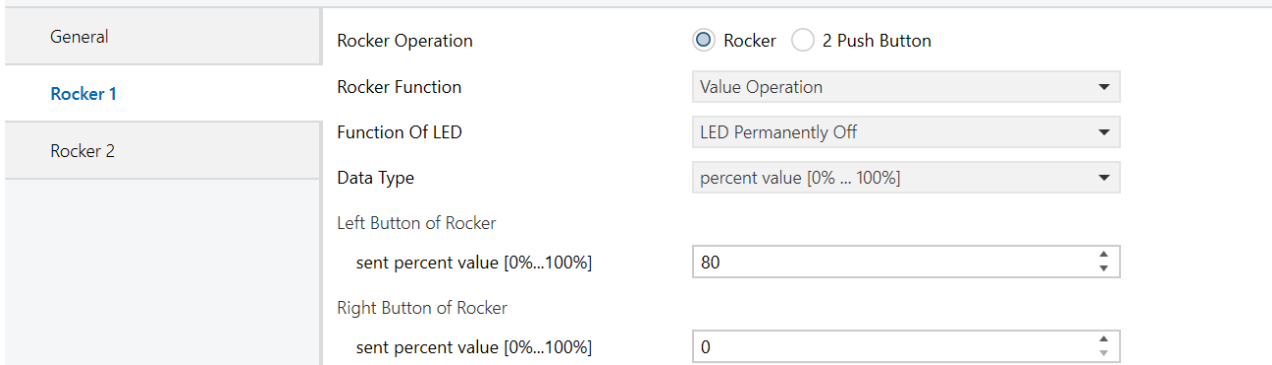

Figure 7

Rocker buttons can be configured to send predefined values from different data types. Values selected for both rocker buttons will be transmitted over the same communication object.

4.2.1.4.1 Parameters

Parameter	Setting	Description
Function of Led	LED Permanently Off	LED always off
	LED Permanently On	LED always on
	Operation Indication	Status LED of the pressed rocker button will be on for the time period selected at “Light Duration of LED” parameter at “General” tab.

Data Type	<b>No Reaction</b> 1 bit value 1 byte value [0...255] Percent value [%0...%100] 2 byte value [-32768...32767] 2 byte value [0...65535] 4 byte value [floating point] 4 byte value [0...4294967295]	Select data type.
Left Button of Rocker		
Sent value	0/1	Visible when "Data Type" selected as "1 bit value".
Transmitted value [0...255]	0...255	Visible when "Data Type" selected as "1 byte value".
Send percent value [%0...%100]	0...80...100	Visible when "Data Type" selected as "percent value".
Transmitted value [-32768...32767]	-32768...0...32767	Visible when "Data Type" selected as "2 byte value [-32768...32767]".
Transmitted value [0...65535]	0...65535	Visible when "Data Type" selected as "2 byte value [0...65535]".
Float decimal	-128...0...127	Visible when "Data Type" selected as "4 byte value [floating point]".
Float rational	0...99	Visible when "Data Type" selected as "4 byte value [floating point]".
Transmitted value [0...4294967295]	0...4294967295	Visible when "Data Type" selected as "4 byte value [0...4294967295]".
Right Button of Rocker – Operate the same way as Left Button of Rocker		

Table 13

#### 4.2.1.4.2 Communication Objects

No	Object Name	Function	Data type	Flags
1	PushButton1 – value[0,1]	True/False	1 bit DPT 1.002	CWT
	Enabled when "Data Type" selected as "1 bit value"			
	PushButton1– value[0...255]	Send	1 byte DPT 5.010	CWT
	Enabled when "Data Type" selected as "1 byte value [0...255]"			
	PushButton1– value[0...255]	Send	1 byte DPT 5.001	CWT
	Enabled when "Data Type" selected as "Percent value [%0...%100]"			
	PushButton1- value[-32768...32767]	Send	2 byte DPT 8.001	CWT
	Enabled when "Data Type" selected as "2 byte value [-32768...32767]"			
	PushButton1- value[0...65535]	Send	2 byte DPT 7.001	CWT
	Enabled when "Data Type" selected as "2 byte value [0...65535]"			
PushButton1- value[temperature]	Send	4 byte DPT 14.068	CWT	
Enabled when "Data Type" selected as "4 byte value [floating point]"				
PushButton1-value[0...4294967295]	Send	4 byte DPT 12.001	CWT	
Enabled when "Data Type" selected as "4 byte value [0...4294967295]"				

2	PushButton1-long – value[0,1]	True/False	1 bit DPT 1.002	CWT
	Enabled when “Long Press Data Type” selected as “1 bit value”			
	PushButton1-long – value[0...255]	Send	1 byte DPT 5.010	CWT
	Enabled when “Long Press Data Type” selected as “1byte value [0...255]”			
	PushButton1– value[0...255]	Send	1 byte DPT 5.001	CWT
	Enabled when “Long Press Data Type” selected as “Percent value [%0...%100]”			
	PushButton1 - long - value[-32768...32767]	Send	2 byte DPT 8.001	CWT
	Enabled when “Long Press Data Type” selected as “2 byte value [-32768...32767]”			
	PushButton1- long -value[0...65535]	Send	2 byte DPT 7.001	CWT
	Enabled when “Long Press Data Type” selected as “2 byte value [0...65535]”			
	PushButton1-long -value[temperature]	Send	4 byte DPT 14.068	CWT
	Enabled when “Long Press Data Type” selected as “4 byte value [floating point]”			
	PushButton1- long - value[0...4294967295]	Send	4 byte DPT 12.001	CWT
Enabled when “Long Press Data Type” selected as “4 byte value [0...4294967295]”				

Table 14

#### 4.2.2 Push Buttons

Number of rockers should be selected in “General” tabs in parameters and should be chosen as compatible with the device that will be configured. Push buttons are numbered from top to bottom – right to left, topmost right push button as push button 1, near it push button 2, and so on. Push buttons can be configured as 4 different operations and 1 function to disable push button (No Function). Operation selection can be configured from “Push Button N” (N: Push button number) tab, visible when “Rocker Operation” selected as “2 Push Buttons”. Every function enables different parameters and communication objects that will be explained in the following chapters.

Parameter	Setting	Description
Push Button Function	<b>No Function</b>	Disables the push button
	Switch	Push buttons can be used to send on/off telegrams. (For more information Chapter 4.2.2.1)
	Switch and Dim	Push buttons can send on/off and dimming telegrams. (For more information Chapter 4.2.2.2)
	Shutter	Push button can control shutter, venetian blind, blind, roller and awning. (For more information Chapter 4.2.2.3)
	Value Operation	Push button can send predefined values from different data types. (Refer Section 4.2.2.4)

Table 15

Push buttons also have status LEDs which can be configured to indicate state of the operation that is configured.



### 4.2.2.1 Switch

1.1.2 SMx Push button > Push Button 1

General	Push Button Function	Switch
Rocker 1	Command On Press	Toggle
<b>Push Button 1</b>	Command On Release	No Command
Push Button 2	Function Of LED	Status Indication
Rocker 2	Separate Comm Object	<input type="radio"/> Enable <input checked="" type="radio"/> Disable

Selecting “Switch” as “Push Button Function“ enables to send 1 bit On(1)/Off(0) telegrams to the group address that is linked to respective communication object. Pressing and releasing buttons can be assigned to different commands (On, Off, Toggle and No Command). Status LEDs can be configured to notify the current status of operation directly with buttons or using communication objects for confirmation to show current status.

#### 4.2.2.1.1 Parameters

Parameter	Setting	Description
Command on Press	On / Off / Toggle / <b>No command</b>	Selects button function when button pressed.
Command on Release	On / Off / Toggle / <b>No command</b>	Selects button function when button released.
Function of LED	<b>LED permanently Off</b>	LED always Off
	LED permanently On	LED always On
	Status Indication	Last transmitted command “on” -> LED on Last transmitted command “off” -> LED off If “Separate Comm Object” enabled, status LEDs will wait for confirmation before changing status.
	Inverted Status Indication	Last transmitted command “on” -> LED off Last transmitted command “off” -> LED on If “Separate Comm Object” enabled, status LEDs will wait for confirmation before changing status.
	Operation Indication	Status LED of the pressed push button will be on for the time period selected at “Light Duration of LED” parameter at “General” tab. Last transmitted command value has no effect to the status led operation.
Separate Comm Object	Enable/ <b>Disable</b>	Only visible when “Function of LED” selected as “Status Indication” or “Inverted Status Indication”. This communication objects is the input of confirmation for status LEDs. If selected “Enable” respective communication object should be linked to an appropriate group address.

Table 16

4.2.2.1.2 Communication Objects

No	Object Name	Function	Data Type	Flags
1	PushButton1	switch	1 bit DPT 1.001	CWT
On/Off telegrams will be send to group address that is linked to this communication object.				
3	PushButton1	Status Comm.Obj.	1 bit DPT 1.002	CWT
Confirmation for On/Off switch telegrams will be received from this communication object. If these communications object visible, it must link to an appropriate group address. Otherwise status LEDs will not function correctly. If status confirmation not to be used the communication object should be disabled by "Separate Comm Object" parameter.				

Table 17

4.2.2.2 Switch and Dim

1.1.2 SMx Push button > Push Button 1

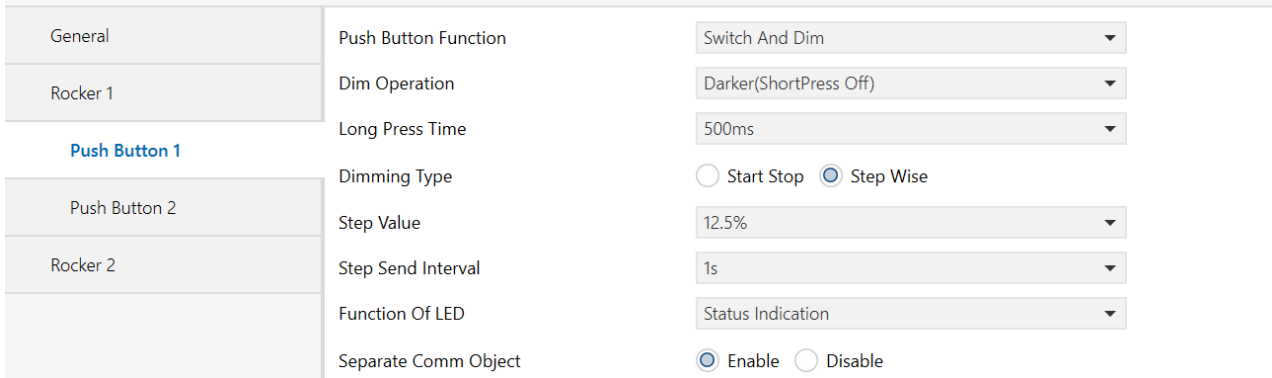

Figure 9

When push button function selected as “Switch and Dim” push button can be configured in three different ways to control brightness value.

	Short Press	Long press
Darker(Short Press Off)	Off (%0)	Decrease, (%XX)
Brighter(Short Press On)	On(%100)	Increase,(%XX)
Darker/Brighter(Short Press Toggle)	Toggle between Darker/Brighter	Decrease,(%XX)/Increase,(%XX)

Table 18

%XX values can have different values relative to the “Dimming Type” parameter. “Dimming Type” parameter allows two different types of dimming functionality “Start Stop” and “Step Wise”.

Dimming - Start Stop Type

When push button pressed (and not released) and pressed duration exceeds “Long Press Duration” time “Increase, %100” (When button in Brighter mode) or “Decrease, %100” (When button in Darker mode) dimming level will be send using respective communication object. When button released “Increase, Break” or “Decrease, Break” value will be send.

Dimming - Step Wise Type

When push button pressed (and not released) and pressed duration exceeds “Long Press Duration” time, a step

value level configured in “Step Value” parameter will be send using respective communication object. If button mode is “Darker”, “Decrease, % [Step Value]”, else button mode is “Brighter”, “Increase, % [Step Value]” values will be send. Until button is released same step value will be send periodically with a time interval defined in “Step Send Interval”.

4.2.2.2.1 Parameters

Parameter	Setting	Description
Dim Operation	<b>Darker(Short Press Off)</b> Brighter(Short Press On) Darker/Brighter (Short Press Toggle)	Select push button dim operation. (For more information Chapter 4.2.2.2)
Long Press Time	300ms/400ms/500ms/600ms/800ms/ <b>1s</b> / 1.2s / 1.5s/ 2s / 3s / 4s / 5s / 6s / 7s / 8s / 9s / 10s	Time interval to switch from “switch/toggle mode” to “dimming mode”.
Dimming Type	<b>Start Stop</b> / Step Wise	Select dimming type. ( For more information Chapter 4.2.2.2)
Step Value	%100 / %50 / %25 / <b>%12.5</b> / %6.25 / %3.13 / % 1.56	Visible when dimming type is Step Wise. Selects the dimming resolution that will be sending at every “Step Send Interval”.
Step Send Interval	300ms/400ms/500ms/600ms/800ms/ <b>1s</b> / 1.2s / 1.5s/ 2s / 3s / 4s / 5s / 6s / 7s / 8s / 9s / 10s	Visible when dimming type is Step Wise. Selects the time interval to send dimming increase/decrease values
Function of LED	<b>LED Permanently Off</b>	LED always off
	LED Permanently On	LED always on
	Status Indication	Last transmitted command “on” -> LED on Last transmitted command “off” -> LED off If “Separate Comm Object” enabled, status LEDs will wait for confirmation before changing status.
	Inverted Status Indication	Last transmitted command “on” -> LED off Last transmitted command “off” -> LED on If “Separate Comm Object” enabled, status LEDs will wait for confirmation before changing status.
	Operation Indication	Status LED of the pressed push button will be on for the time period selected at “Light Duration of LED” parameter at “General” tab.
Separate Comm Object	<b>Enable / Disable</b>	Only visible when “Function of LED” selected as “Status Indication” or “Inverted Status Indication”. This communication objects is the input of confirmation for status LEDs. If selected “Enable” respective communication object should be linked to an appropriate group address.

Table 19

#### 4.2.2.2.2 Communication Objects

No	Object Name	Function	Data type	Flags
1	PushButton1 – switch	On/Off	1 bit DPT 1.001	CWT
On/Off telegrams will be send to group address that is linked to this communication object.				
2	PushButton1 – dimming	Dim	4 bit DPT 3.007	CWT
Dimming values will be send to group address that is linked to this communication object.				
3	PushButton1-Status Comm.Obj.	On/Off	1 bit DPT 1.002	CWT
Confirmation for On/Off switch telegrams will be received from this communication object. If these communications object visible, it must link to an appropriate group address. Otherwise status LEDs will not function correctly. If status confirmation not to be used the communication object should be disabled by “Separate Comm Object” parameter.				

Table 20

#### 4.2.2.3 Shutter

1.1.2 SMx Push button > Push Button 1

General	Push Button Function	Shutter
Rocker 1	Button Function	Up
<b>Push Button 1</b>	Control Type	<input checked="" type="radio"/> Shutter/Venetian blind <input type="radio"/> Blind/Roller/Awning
Push Button 2	Function Of LED	Status Indication
Rocker 2	Long Press Duration	300ms
	Long Press --> Up/Down, Short Press --> Stop/Lamella Adj.	

Figure 10

Selecting “Shutter” for “Push Button Function” enables shutter operation for push buttons. Shutter functions can be configured to control two different shutter operations “Shutter/Venetian Blind” function or “Blind/Roller/Awning” function. In both functions push button can be configured as 3 different button function; Up, Down and Toggle. When push button selected as up or down, that button can only move the blind and lamella to the configured direction. For example, if configured as up button, push button can be used to move the blind up and adjust the lamella down. If push button configured as toggle button, single button can be used to move the blind up – down and adjust lamella up – down.

##### Shutter/Venetian Blind Function

When “Controller Type” configured as “Shutter/Venetian Blind”, lamella operations of blind control will be enabled as “shortpress” function of the push button. Also, “Button Function” parameter enables the use of push button 3 different ways;

Up: “Long Press” moves the blind upwards; “Short Press” operates two different ways, short pressed while the blind is moving, stops the blind, short pressed while the blind is not moving adjust the lamella position down.

Down: “Long Press” moves the blind downwards; “Short Press” operates two different ways, short pressed while the blind is moving, stops the blind, short pressed while the blind is not moving adjust the lamella position up.

Toggle: “Long Press” moves the blind upwards or downwards toggling the last “Long Press” action. For example, if last state was up, when push button long pressed, it will send “Down” telegram. Every time



push button long pressed it will toggle its last state. If push button short pressed while the blind is moving upward or downward “Short Press” will stop the blind, if the blind is not moving “Short Press” will adjust the lamella. Lamella adjustment will operate respective to the last state, for example if the last “Long Press” action was up, then lamella will be adjusted down when push button short pressed and if the last “Long Press” action was down, then lamella will be adjusted up when push button short pressed.

**Blind/Roller/Awning Function**

When “Controller Type” configured as “Blind/Roller/Awning Function” lamella operations of blind control will be disabled and “shortpress” will only stop the movement of the blind. “ButtonFunction” parameter enables the use of push button 3 different ways;

Up: “Long Press” moves the blind upwards; “Short Press” stops the blind.

Down: “Long Press” moves the blind downwards; “Short Press” stops the blind.

Toggle: “Long Press” action moves the blind upwards or downwards toggling the last “Long Press” action. For example, if last state was up, when push button long pressed it will send “Down” telegram. Everytime push button long pressed it will toggle its last state. “Short Press” stops the blind whether it’s moving upwards or downwards

**4.2.2.3.1 Parameters**

Parameter	Setting	Description
Push Button Function	<b>Up / Down / Toggle</b>	Chapter 4.2.2.3
Control Type	<b>Shutter/Venetian Blind</b> Blind/Roller/Awning	Selects control type of blinds. Shutter/Venetian Blind function includes “Lamella Control” and Blind/Roller/Awning function does not include “Lamella Control”.
Function of LED	<b>LED Permanently Off</b>	LED always off
	LED Permanently On	LED always on
	Status Indication	Visualize blind’s state using status LEDs of up and down buttons. <b>*[6]</b>
	Operation Indication	Status LED of the pressed rocker button will be on for the time period selected at “Light Duration of LED” parameter at “General” tab.
Long Press Duration	<b>300ms/ 400ms/ 500ms/ 600ms/ 800ms/ 1s / 1.2s/ 1.5s/ 2s / 3s / 4s / 5s / 6s / 7s / 8s / 9s / 10s</b>	Time interval to switch from short press to long press

Table 21

**4.2.2.3.2 Communication Objects**

**\*[6] LED Function – Status Indication**

Status indication operates the same way for “Shutter/Venetian Blind” and “Blind/Roller/Awning”. LEDs status respective to blind’s state and “Button Function” configuration given below;

	Up Mode	Down Mode	Toggle Mode
Moving upward	Blink	Off	Blink

Moving downward	Off	Blink	Blink
At top position	Off	Off	Off
At bottom position	Off	Off	Off
Stop between top - bottom	Off	Off	Off

Table 22

When “Function of Led” selected as “Status Indication”, “Top Position” and “Bottom Position” communication objects given below must be linked to the appropriate group addresses for the LEDs to function correctly.

#### 4.2.2.4 Value Operation

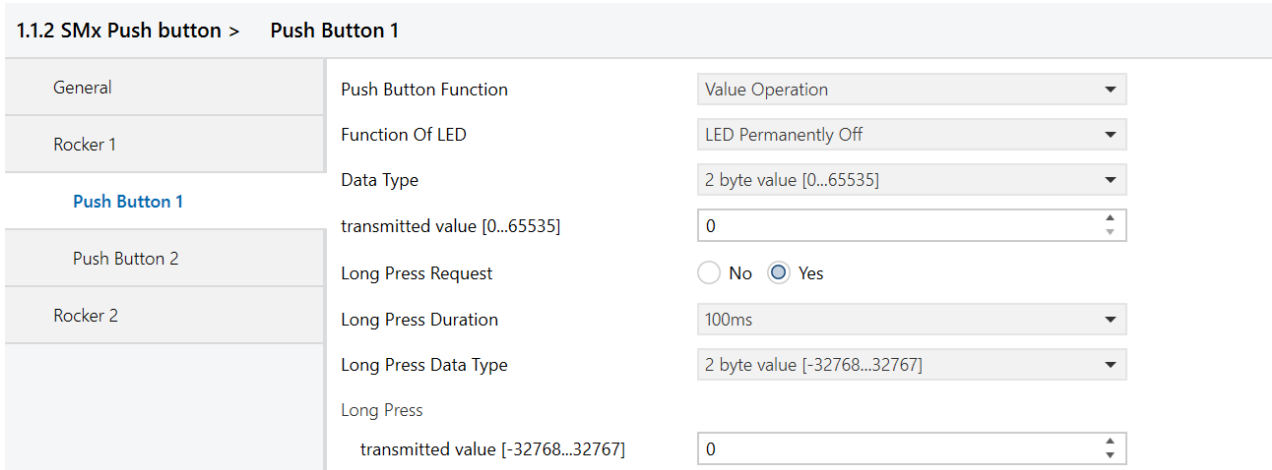

Figure 11

Push button can be configured to send predefined values from different data types. Additionally, a long press request can be enabled to be used as a secondary value operation.

##### 4.2.2.4.1 Parameters

Parameter	Setting	Description
Function of Led	<b>LED Permanently Off</b>	LED always off
	LED Permanently On	LED always on
	Operation Indication	Status LED of the pressed rocker button will be on for the time period selected at “Light Duration of LED” parameter at “General” tab.
Data Type	<b>No Reaction</b> 1 bit value 1 byte value [0...255] Percent value [%0...%100]	Select data type.
	2 byte value [-32768...32767] 2 byte value [0...65535] 4 byte value [floating point] 4 byte value [0...4294967295]	
Sent value	0/1	Visible when “Data Type” selected as “1 bit value”.
Transmitted value [0...255]	0...255	Visible when “Data Type” selected as “1 byte value”.
Send percent value [%0...%100]	0...80...100	Visible when “Data Type” selected as “percent value”.
Transmitted value [-32768...32767]	-32768...0...32767	Visible when “Data Type” selected as “2 byte value [-32768...32767]”.



Transmitted value [0...65535]	0...65535	Visible when "Data Type" selected as "2 byte value [0...65535]".
Float decimal	-128...0...127	Visible when "Data Type" selected as "4 byte value [floating point]".
Float rational	0...99	Visible when "Data Type" selected as "4 byte value [floating point]".
Transmitted value [0...4294967295]	0...4294967295	Visible when "Data Type" selected as "4 byte value [0...4294967295]".
Long Press Request	No / Yes	Enable/Disable long press duration
Long Press Duration	100ms / 1s / 10s / 1min / 10min	Select time period for long press operation
Long Press Data Type	<b>No Reaction</b> 1 bit value 1 byte value [0...255] Percent value [%0...%100] 2 byte value [-32768...32767] 2 byte value [0...65535] 4 byte value [floating point] 4 byte value [0...4294967295]	Select data type.
Sent value	0/1	Visible when "Long Press Data Type" selected as "1 bit value".
Transmitted value [0...255]	0...255	Visible when "Long Press Data Type" selected as "1 byte value".
Send percent value [%0...%100]	0...80...100	Visible when "Long Press Data Type" selected as "percent value".
Transmitted value [-32768...32767]	-32768...0...32767	Visible when "Long Press Data Type" selected as "2 byte value [-32768...32767]".
Transmitted value [0...65535]	0...65535	Visible when "Long Press Data Type" selected as "2 byte value [0...65535]".
Float decimal	-128...0...127	Visible when "Long Press Data Type" selected as "4 byte value [floating point]".
Float rational	0...99	Visible when "Long Press Data Type" selected as "4 byte value [floating point]".
Transmitted value [0...4294967295]	0...4294967295	Visible when "Long Press Data Type" selected as "4 byte value [0...4294967295]".

Table 23